



Earth Anchors

furniture for parks and streets.

Seat & Benches Data Sheet

Forest Saver Seat



Colour Information:

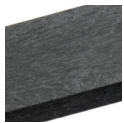

Black

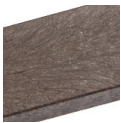

Brown



RAL 6005



RAL 9005



RAL 1021



RAL 5010



RAL 3003

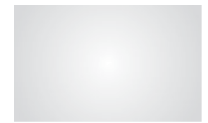

Galvanised

Specification:

Seat length: 1800mm

Seat height: 510mm

Weight: 79.2kg

Product Information

Description

A simple steel framed park seat with recycled plastic slats. Frames paintable in a selection of colours.

Features

Supplied flat packed – 8 pieces.

Tamperproof fittings.

Powder coated frames.

Materials

Mild steel.

Forest-Saver recycled plastic.

Optional Extras

Arm Rests.

Customise with engravings or plaques.

Ground fixing kits.



Earth Anchors Ltd

Unit 3 Io Centre, Salbrook Road Industrial Estate, Salfords, Surrey, RH1 5GJ

Tel: 020 8684 9601

www.earth-anchors.com



Earth Anchors

furniture for parks and streets.

Seat & Benches Data Sheet

Forest Saver Seat

Ground Fixings

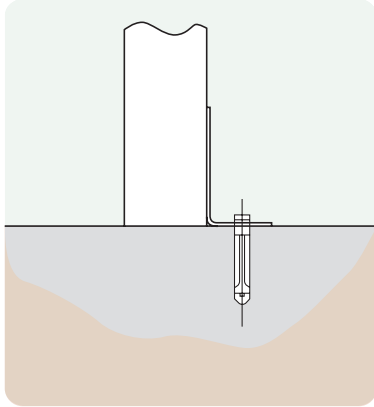

Bolt down
Available for a variety of hard surfaces.

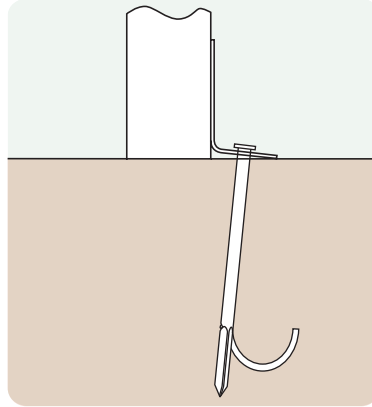

Anchored
Soft ground fixing kit for grass.

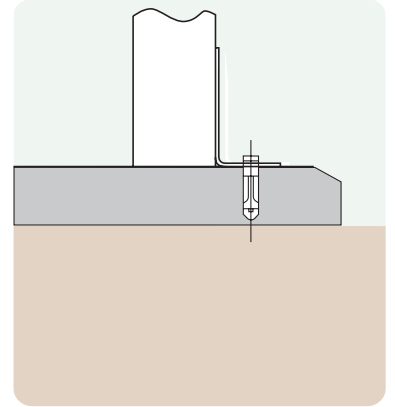

FastDek
Envirofriendly alternative to a concrete pad.

Additional Data

Total weight: 79.2kg

Legs: 7.4kg

Seat slats: 11.4kg

Side View

Top View

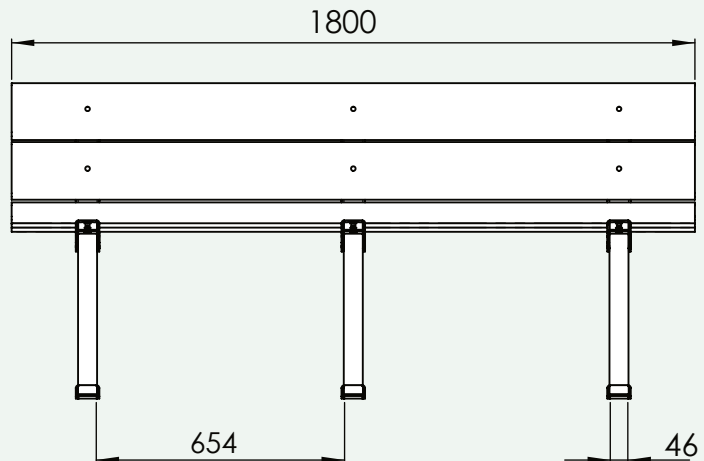
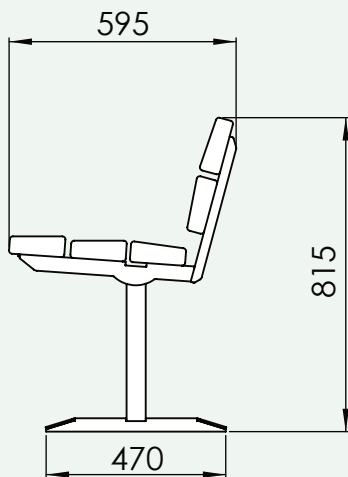

Earth Anchors Ltd

Unit 3 lo Centre, Salbrook Road Industrial Estate, Salfords, Surrey, RH1 5GJ

Tel: 020 8684 9601

www.earth-anchors.com