

**Straight Modular Bench Assembly Instructions**

Parts Supplied	Tools Required
1 Bench section 3 Leg sections 12no. 70mm Stainless screws	Power drill with PZ2 bit Measuring tape Square Mallet

**Assembly Instructions:**  
 Place the bench upside down on a flat surface.  
 Push the legs down onto the bench ends and centre and fix in place with the supplied screws.  
 The legs may require a mallet to push them in to location  
 Ensure the legs are flush with the top face of the bench and square.

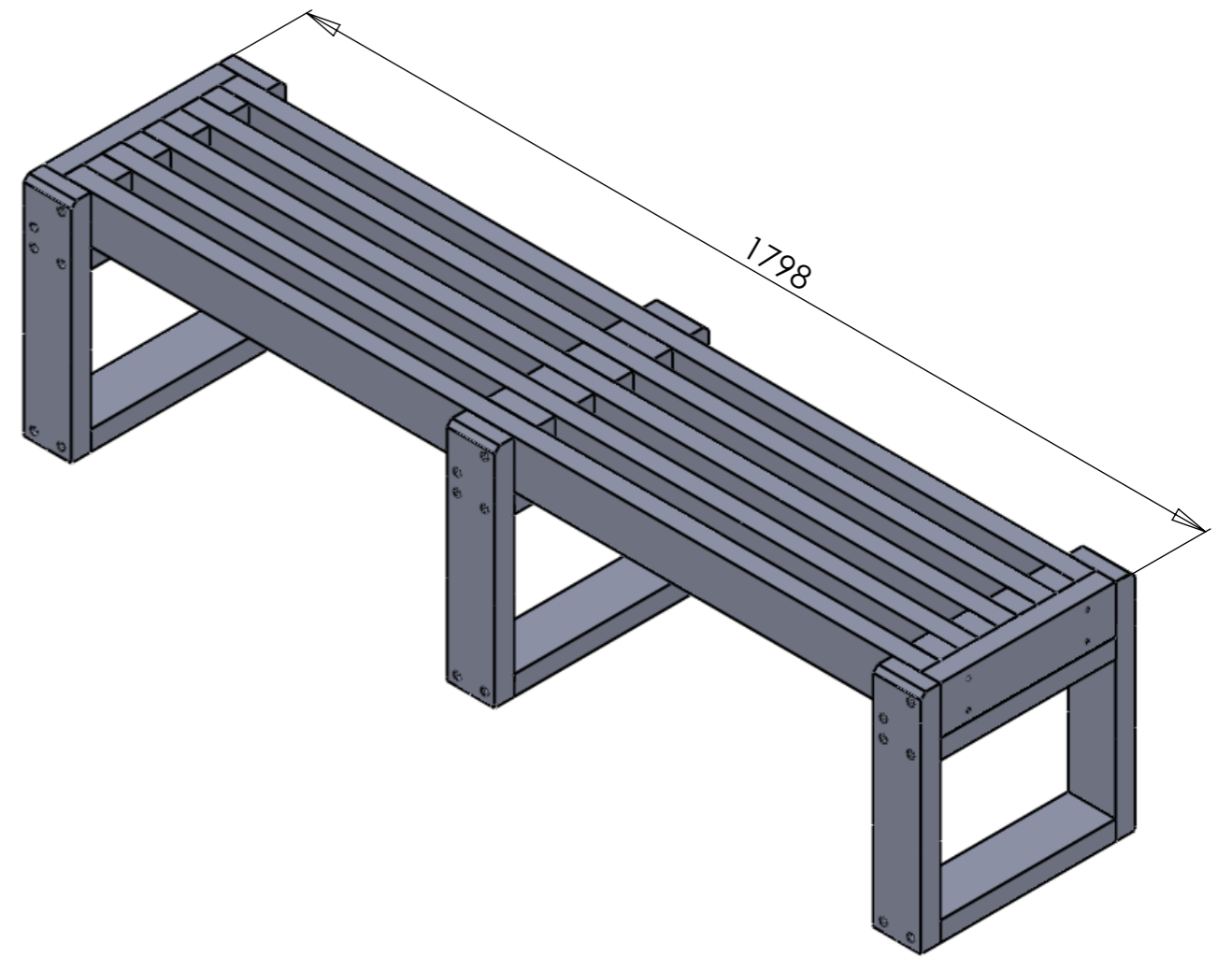
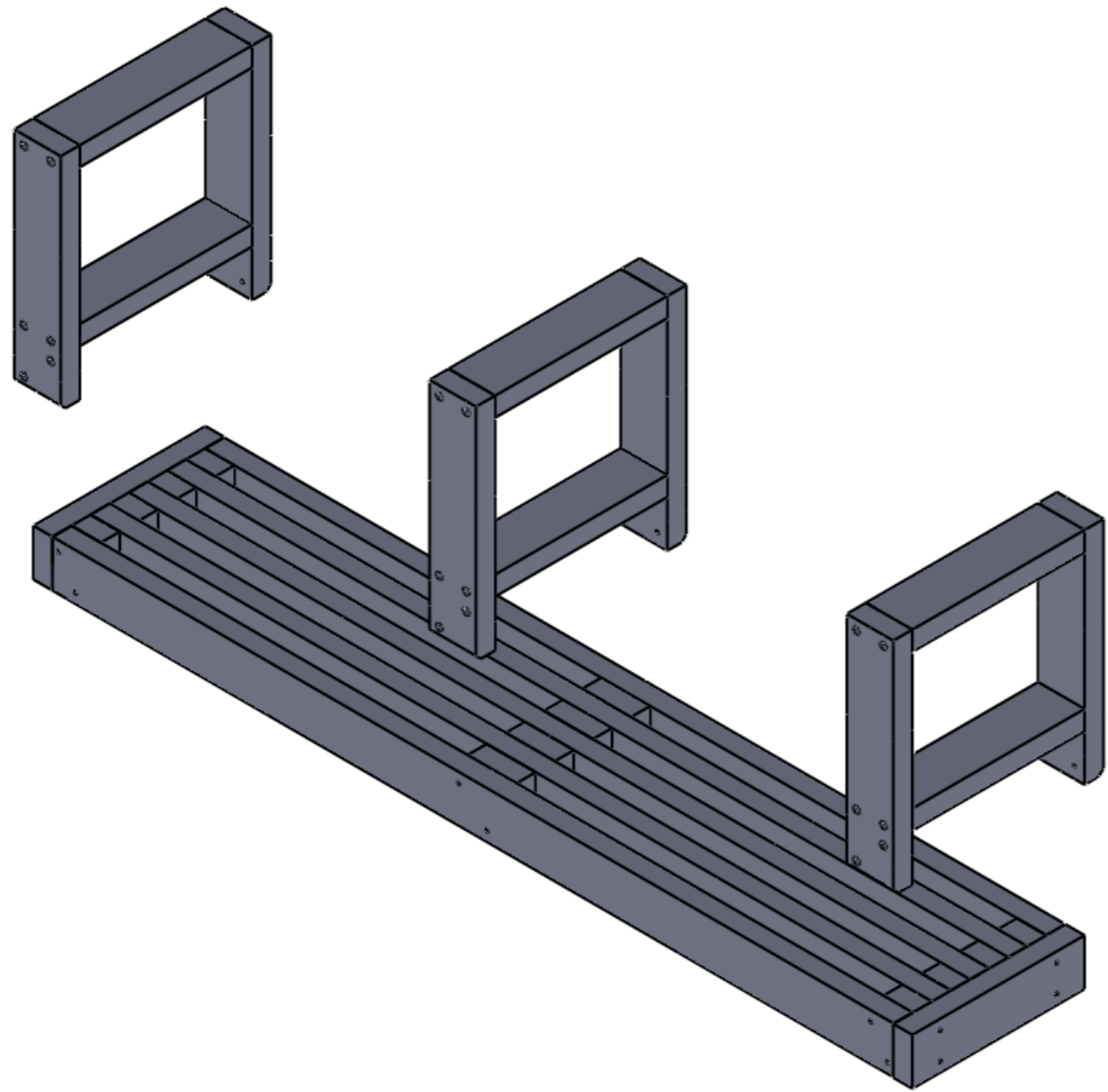

TITLE: Straight Modular Bench Assembly Instructions			
DRAWN	NAME	DATE	REVISION
SW-DWG NAME:		DWG NO.	
			SHEET 1 OF 1