



Earth Anchors

furniture for parks and streets.

# Seat & Benches Data Sheet

## Modular Curved Bench



### Colour Inform

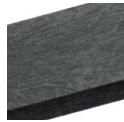

Black



Brown

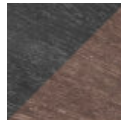

Mixed

### Specification:

Seat length: 2091mm

Seat height: 450mm

Weight: 51kg

### Product Information

#### Description

A simple but robust curved recycled plastic bench with 3 legs. Ideal for joining together to make a continuous curved form. Available in black, brown or mixed.

#### Features

Supplied flat packed – 5 pieces.  
Rust proof fixings.  
25-year material guarantee.

#### Materials

Forest-Saver recycled plastic.  
Stainless Steel.

#### Optional Extras

Ground fixing kits.



Earth Anchors Ltd

Unit 3 Io Centre, Salbrook Road Industrial Estate, Salfords, Surrey, RH1 5GJ

Tel: 020 8684 9601

[www.earth-anchors.com](http://www.earth-anchors.com)



Earth Anchors

furniture for parks and streets.

# Seat & Benches Data Sheet

## Modular Curved Bench

### Ground Fixings

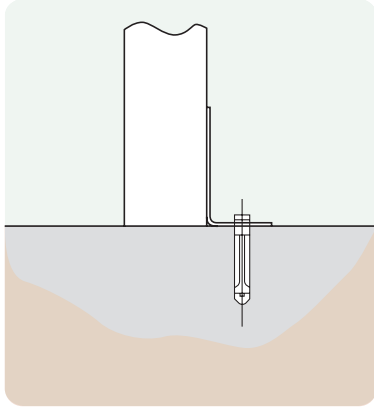

**Bolt down**  
Available for a variety of hard surfaces.

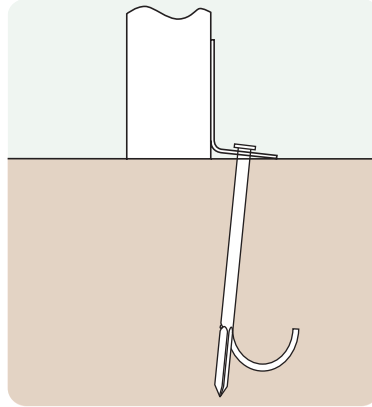

**Anchored**  
Soft ground fixing kit for grass.

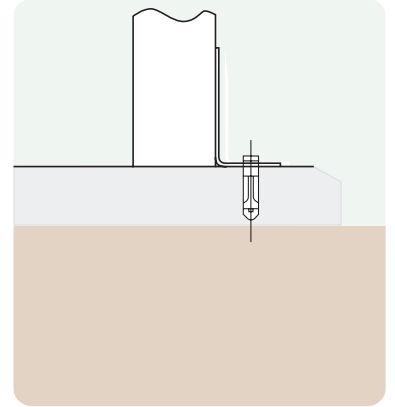

**FastDek**  
Envirofriendly alternative to a concrete pad.

### Additional Data

Total weight: 51kg

Legs: 5kg

Bench assembly: 36kg

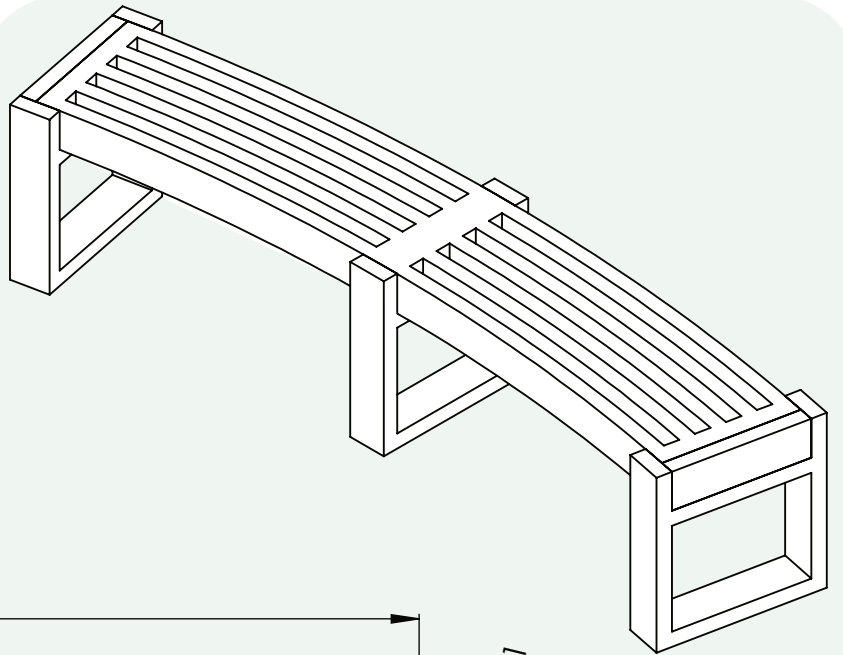

### Top View

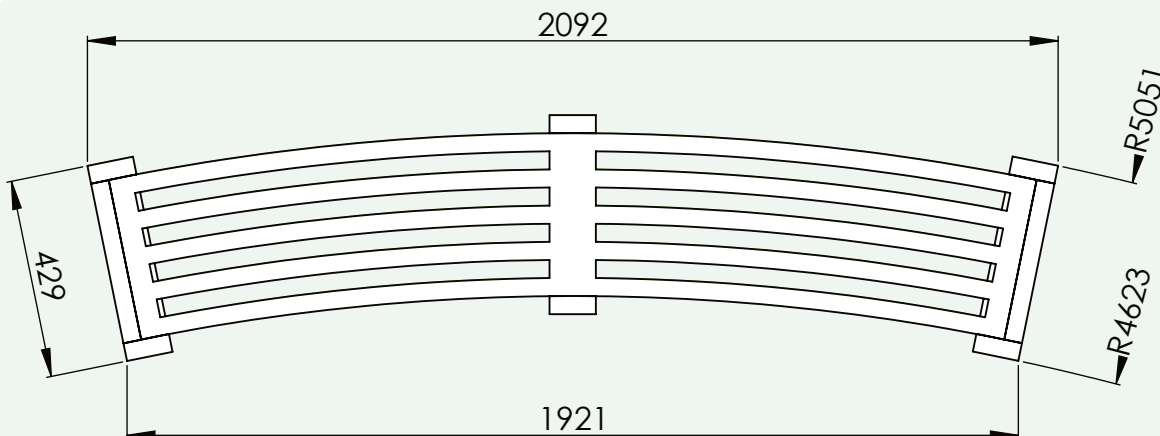

Earth Anchors Ltd

Unit 3 lo Centre, Salbrook Road Industrial Estate, Salfords, Surrey, RH1 5GJ

Tel: 020 8684 9601

www.earth-anchors.com