



Earth Anchors

furniture for parks and streets.

Seat & Benches Data Sheet

Monolith Bench



Colour Information:

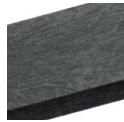

Black



Brown

Specification:

Seat length: 1300 / 1500 / 1800mm

Seat height: 450mm

Weight: 46 / 51 / 60kg

Product Information

Description

A recycled plastic gallery style bench. Available in black or brown and three different lengths – 1.3, 1.5 & 1.8m

Features

Supplied fully assembled.
Rust proof fixings
25-year material guarantee

Materials

Forest-Saver recycled plastic – 80 x 80mm
Stainless Steel

Optional Extras

Customise with engravings or plaques.
Ground fixing kits



Earth Anchors Ltd

Unit 3 lo Centre, Salbrook Road Industrial Estate, Salfords, Surrey, RH1 5GJ

Tel: 020 8684 9601

www.earth-anchors.com



Earth Anchors

furniture for parks and streets.

Seat & Benches Data Sheet

Monolith Bench

Ground Fixings

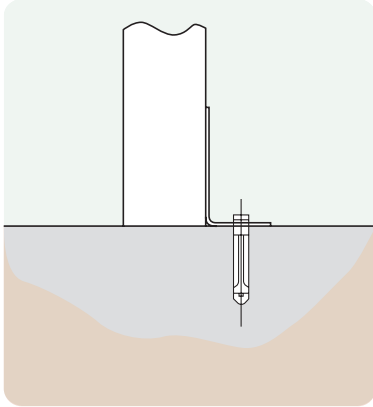

Bolt down
Available for a variety of hard surfaces.

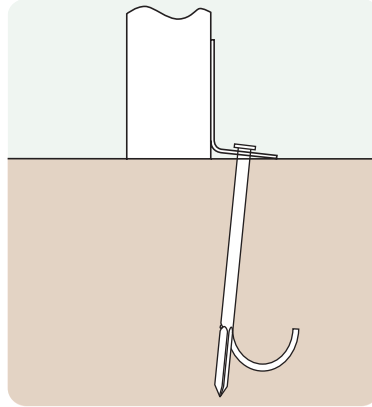

Anchored
Soft ground fixing kit for grass.

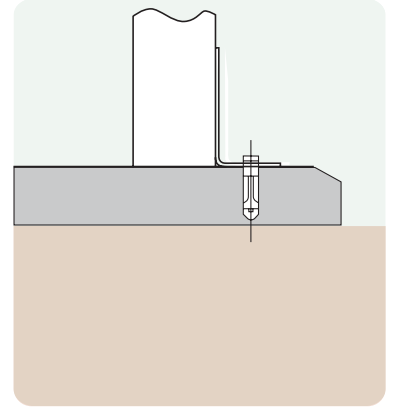

FastDek
Envirofriendly alternative to a concrete pad.

Isometric View

Additional Data

Total weight: 64kg
Top weight: 20kg
Bench weight: 7kg
Leg weight: 15kg

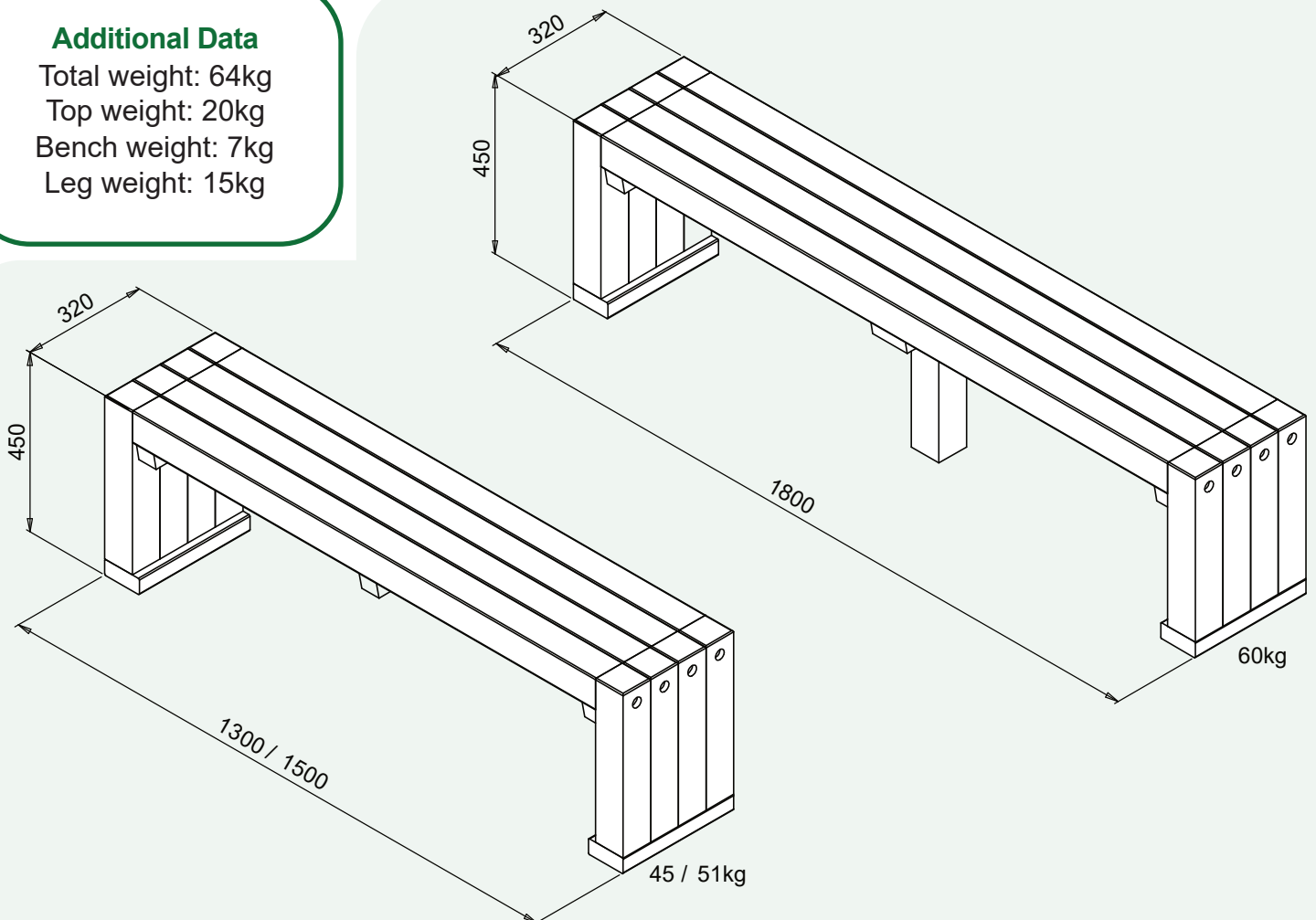

Earth Anchors Ltd
Unit 3 Io Centre, Salbrook Road Industrial Estate, Salfords, Surrey, RH1 5GJ
Tel: 020 8684 9601
www.earth-anchors.com