



Earth Anchors

furniture for parks and streets.

# Table Data Sheet

## Octagonal Picnic Table



### Colour Information:

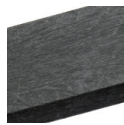

Black

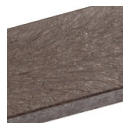

Brown

### Specification:

Table top Width: 1200mm

Seat width: 875mm

Table height: 730mm

Seat height 425mm

Weight: 150Kg

### Product Information

#### Description

Octagonal picnic table for 8 people. Made entirely from Forest-Saver Recycled Plastic.

#### Features

Parasol hole included - 47mm.

Supplied partially assembled - 5 pieces.

Guaranteed for 25 years against material failure.

#### Materials

Forest-Saver recycled plastic.

Stainless steel fittings.

#### Optional Extras

Personalisation with engravings or plaques

Ground fixing kits.



Earth Anchors Ltd

Unit 3 lo Centre, Salbrook Road Industrial Estate, Salfords, Surrey, RH1 5GJ

Tel: 020 8684 9601

www.earth-anchors.com



Earth Anchors

furniture for parks and streets.

# Table Data Sheet

## Octagonal Picnic Table

### Ground Fixings

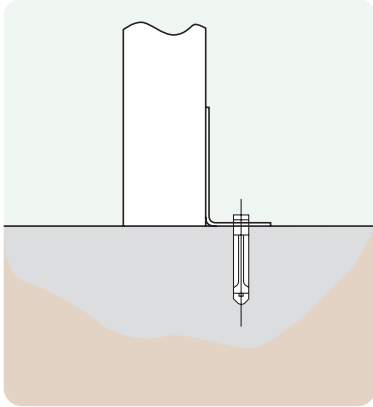

**Bolt down**  
Available for a variety of hard surfaces.

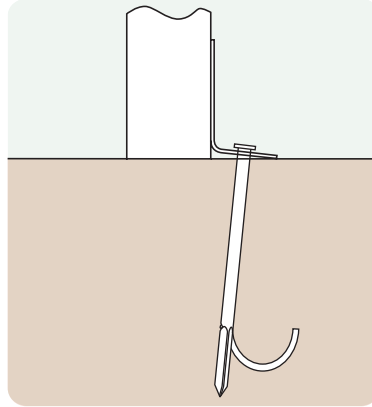

**Anchored**  
Soft ground fixing kit for grass.

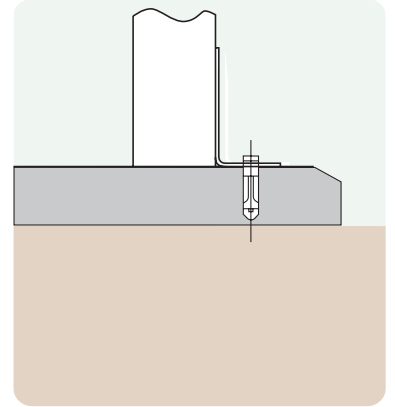

**FastDek**  
Envirofriendly alternative to a concrete pad.

### Top View

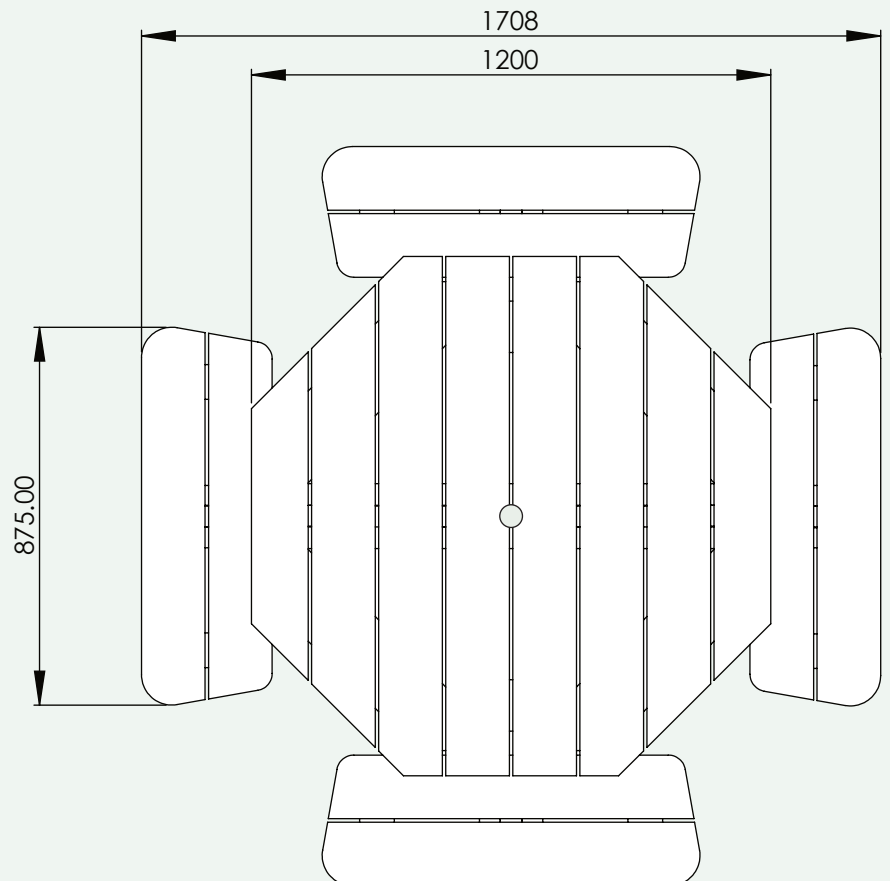

#### Additional Data

Total weight: 150kg  
Table weight: 102kg  
Bench weight: 12kg



Earth Anchors Ltd

Unit 3 Io Centre, Salbrook Road Industrial Estate, Salfords, Surrey, RH1 5GJ

Tel: 020 8684 9601

www.earth-anchors.com