

# INSTALLATION INSTRUCTIONS RANGER SEAT WITH ARMRESTS

DOC REF: 428 ISSUE 01

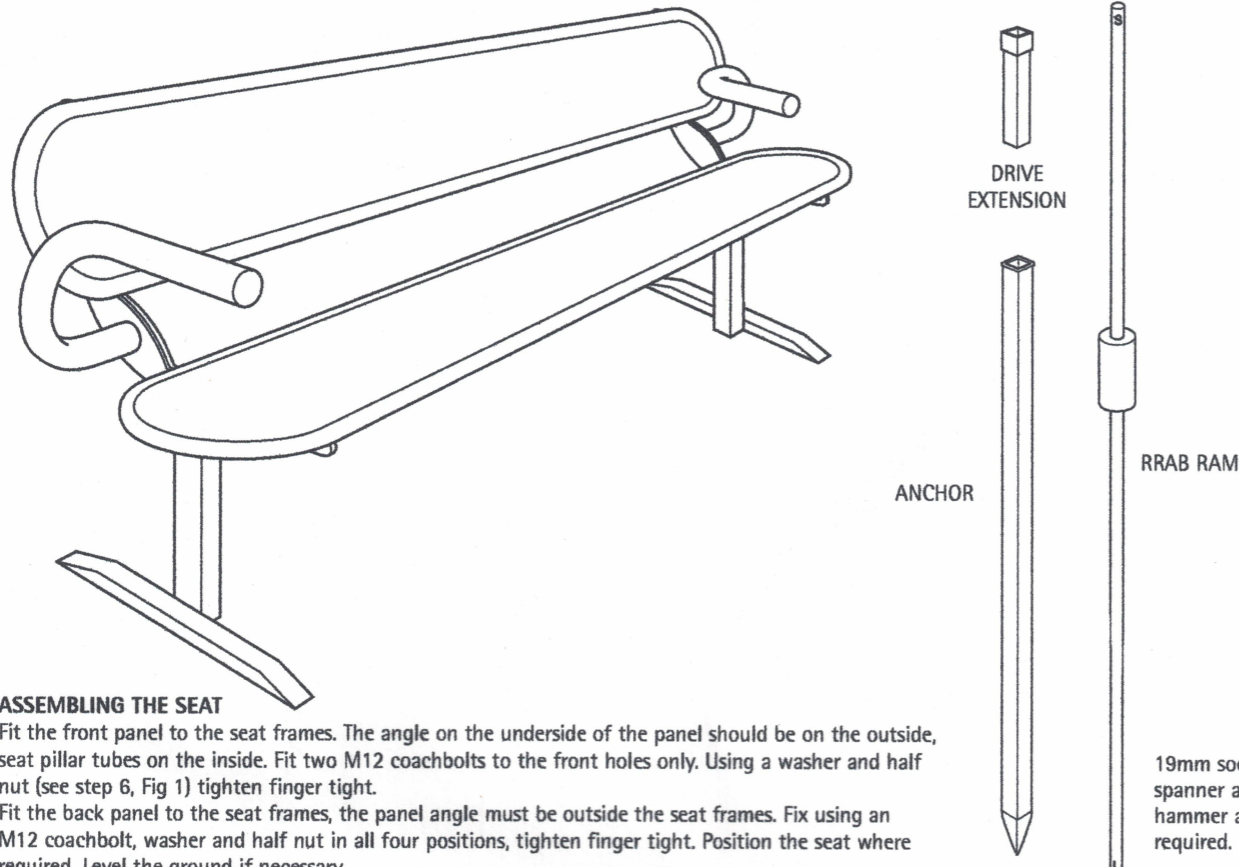

**ASSEMBLING THE SEAT**  
Fit the front panel to the seat frames. The angle on the underside of the panel should be on the outside, seat pillar tubes on the inside. Fit two M12 coachbolts to the front holes only. Using a washer and half nut (see step 6, Fig 1) tighten finger tight.  
Fit the back panel to the seat frames, the panel angle must be outside the seat frames. Fix using an M12 coachbolt, washer and half nut in all four positions, tighten finger tight. Position the seat where required. Level the ground if necessary.

DRIVE EXTENSION  
ANCHOR  
RRAB RAMROD  
19mm socket spanner and hammer also required.

**3**

**ANCHORING**  
Insert the drive extension into the anchor.  
Insert the **Short end** of the ramrod into the anchor through the drive extension.

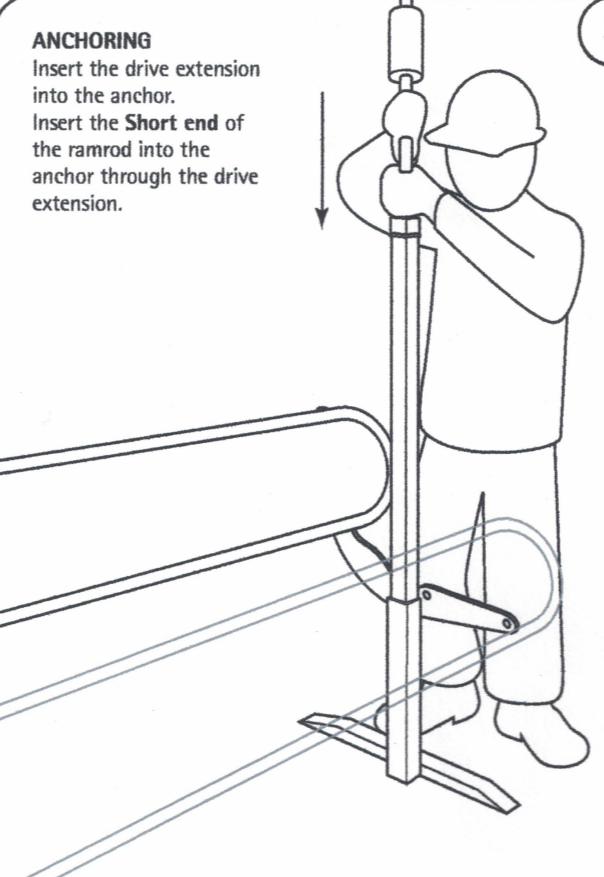

**4**

Lift and ram down the ramrod until the anchor collar meets the end of the seat tube

Repeat the operation for the other anchor. Check the seat is level.

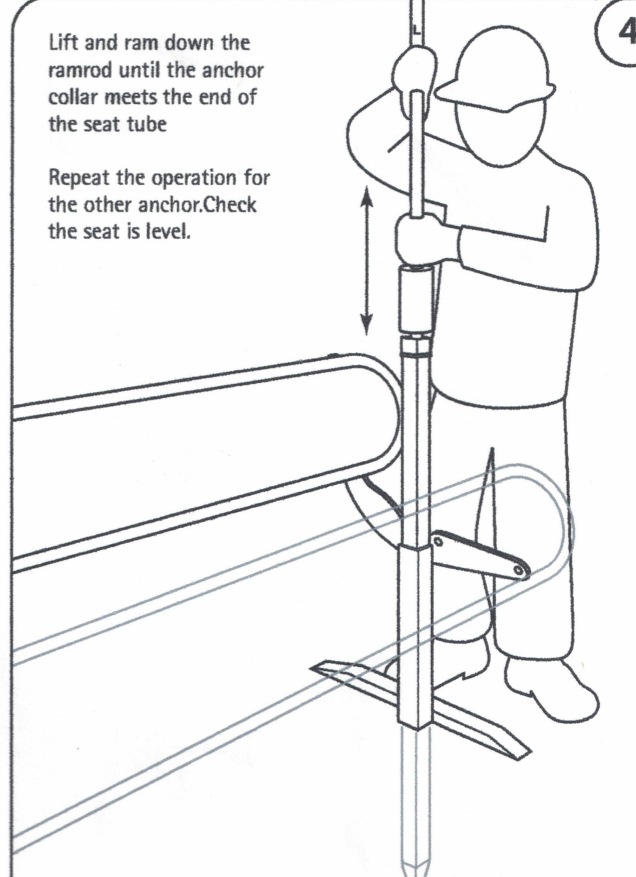

**1**

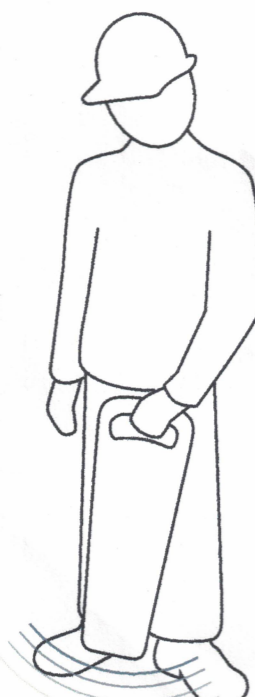
**Always check for buried services**

**2**

**ANCHORING**  
Pivot the seat panel forwards to expose the pillar tube.  
Insert an anchor into the seat tube.

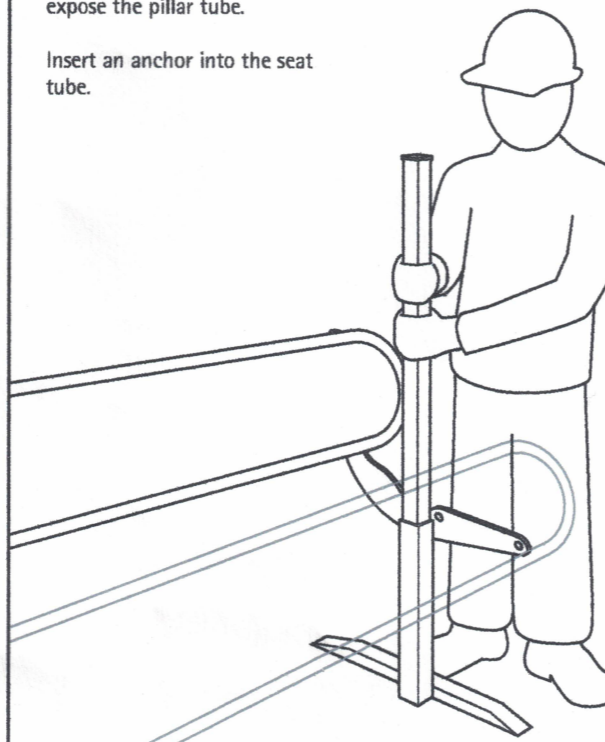

**5**

**DRIVING THE ANCHOR FLUKES**  
Withdraw the ramrod and insert the **long end**. Lift and ram down the ramrod to drive out the flukes.  
Remove the ramrod and drive extension. Pivot back the seat panel.

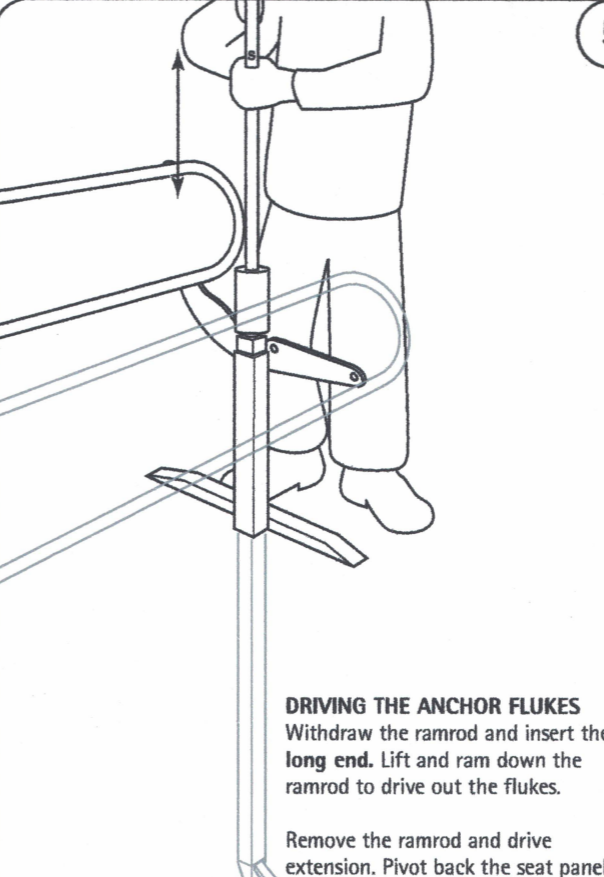

**6**

**FIG. 1**  
SEAT PANEL ANGLE  
HALF NUT  
SHEARNUT  
WASHERS  
COACHBOLT

**FIG. 2**  
SEAT PANEL ANGLE  
HALF NUT  
SHEARNUT  
WASHERS  
SEAT FRAME  
COACHBOLT  
ARMREST BRACKET

**FINAL ASSEMBLY OF THE SEAT**  
Before fitting coachbolt (1) remove coach bolt (2) and attach armrest. Secure at position (1&2) with M12 coachbolts, washers and half nuts on both sides. Tighten all 8 nuts up hard on both panels making sure the coach bolt heads are flush with the framework. Next fit another washer followed by a Shearnut onto all 8 coach bolts. Shear the hexagon heads off the Shearnuts.

**Caution:** Shearing of the nuts can usually be sensed but we advise the wearing of gloves during tightening of nuts to prevent possible skinning of knuckles.

