

PARTS LIST - 2 PERSON ASSEMBLY:-		
A	PRE-ASSEMBLED TABLE TOP	1 no.
B	END A-FRAME	2 no.
C	MIDDLE A-FRAME	1 no.
D	PRE-ASSEMBLED BENCH	2 no.
E	70mm S/STEEL SCREWS	60 no.
F	90mm S/STEEL SCREWS	24 no.

TOOLS:-	
POWER DRILL WITH PZ2 BIT	
G CLAMPS	

**IMPORTANT:-**

Ensure that you are familiar with these assembly instructions prior to commencing assembly.

We will not accept any claims resulting from products that have been wrongly assembled.

Employ safe lifting procedures when handling components.

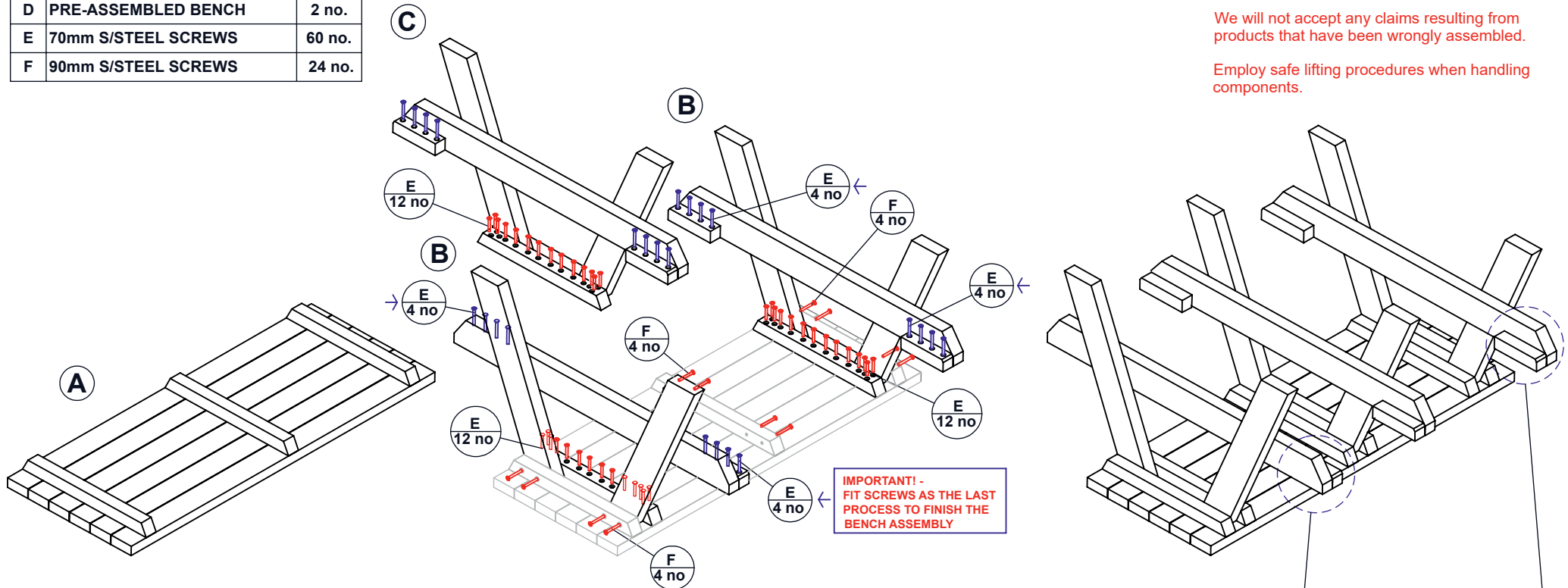

BEGIN ASSEMBLY WITH TABLE TOP TURNED UPSIDE DOWN

USE CLAMPS TO HOLD A-FRAMES TO TABLE BLOCKS  
 FIX A-FRAMES TO TABLE TOP USING USING 70MM SCREWS THROUGH VERTICAL HOLES  
 AND 90MM SCREWS THROUGH HORIZONTAL HOLES  
 ENSURE THE SCREWS ENTER THROUGH THE COUNTER SUNK SIDE OF THE HOLE.

**IMPORTANT - ONLY SCREW THROUGH SIDES WITH COUNTER SUNK HOLE.**

ENSURE END A-FRAMES HAVE THE SEAT FIXING BLOCKS FACING INWARDS AS SHOWN

Help and support:-  
 Please contact us on 020 8684 9601 or email [info@earth-anchors.com](mailto:info@earth-anchors.com)

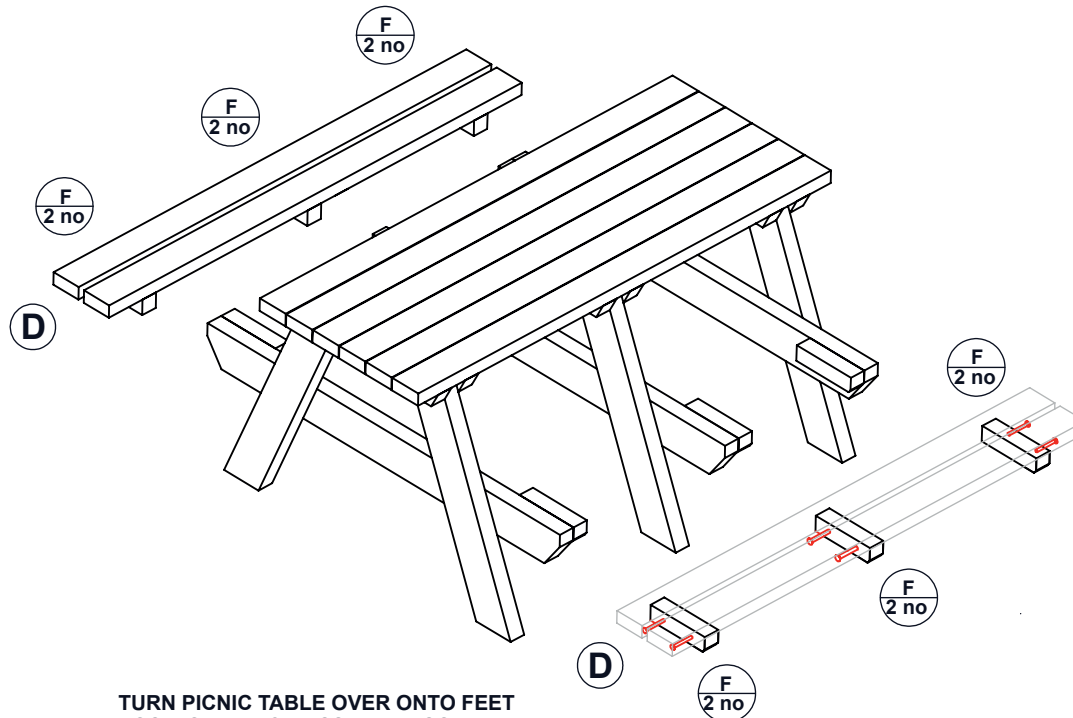
**TOOLS:-****POWER DRILL WITH PHILIPS-HEAD BIT****G CLAMPS**

TURN PICNIC TABLE OVER ONTO FEET  
 POSITION BENCH ASSEMBLY SO THAT THE  
 BLOCKS UNDERNEATH ARE FLUSH TO THE END OF THE LEGS  
 SCREWS THROUGH HORIZONTAL BENCH HOLES (D)  
 IN TO THE LEG ASSEMBLY

**IMPORTANT - USING THE REMAINING 70MM SCREWS  
 THROUGH VERTICAL HOLES AS SHOWN ON PAGE 1 OF 2**

**IMPORTANT:-**

Ensure that you are familiar with these assembly instructions prior to commencing assembly.

We will not accept any claims resulting from products that have been wrongly assembled.

Employ safe lifting procedures when handling components.

