

INSTALLATION INSTRUCTIONS EVERGREEN SEAT ASSEMBLY

DOC REF: 449 ISSUE 01

Make sure the seat is assembled close to where it is to be installed.

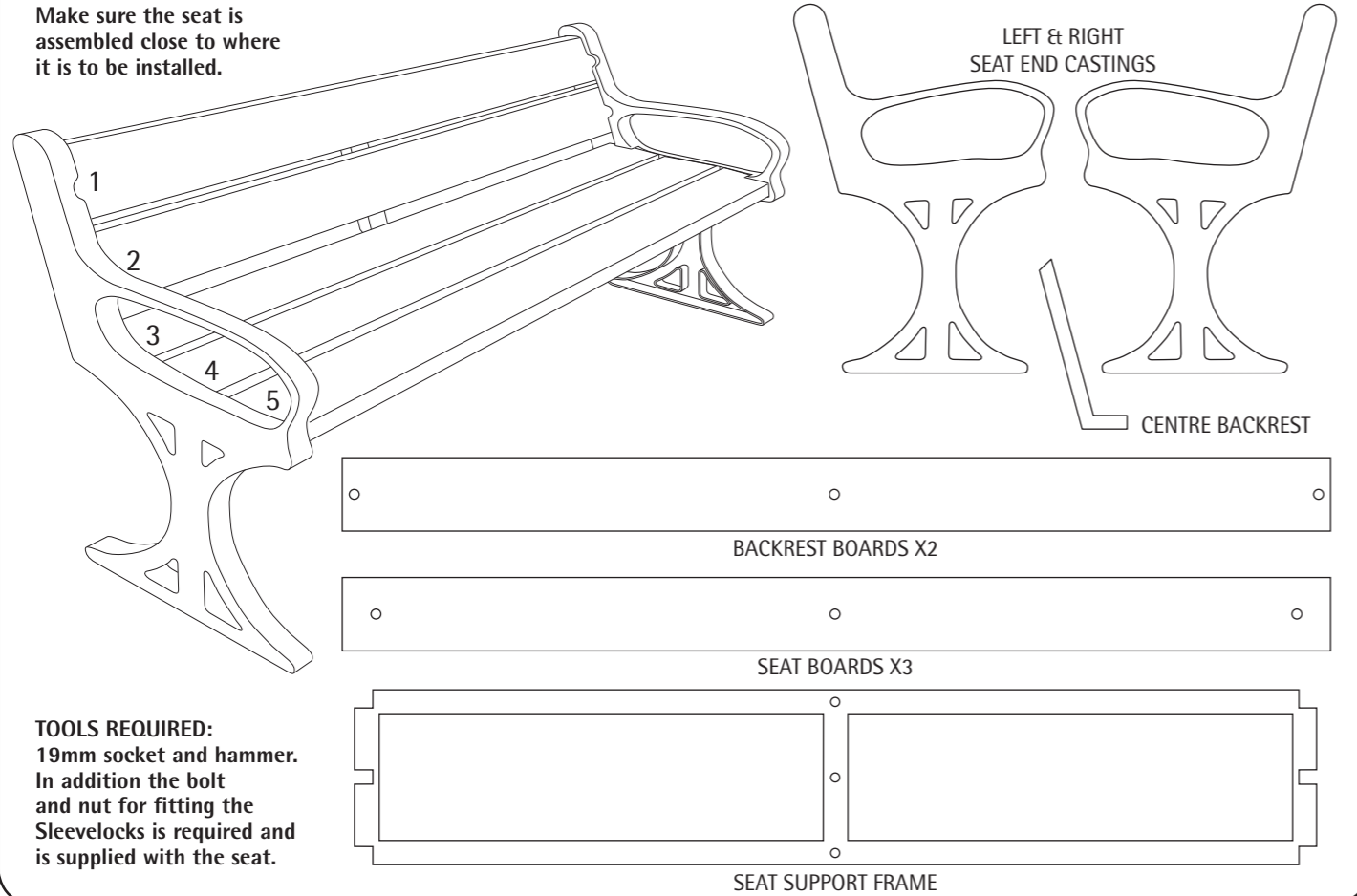

TOOLS REQUIRED:
19mm socket and hammer.
In addition the bolt and nut for fitting the SleeveLocks is required and is supplied with the seat.

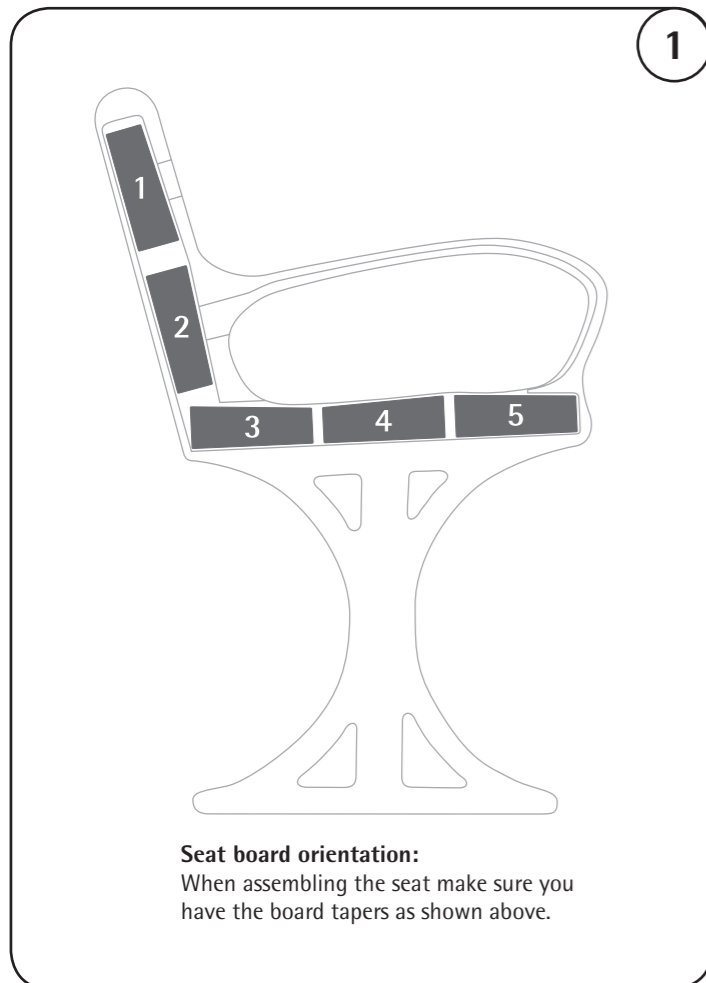

Seat board orientation:
When assembling the seat make sure you have the board tapers as shown above.

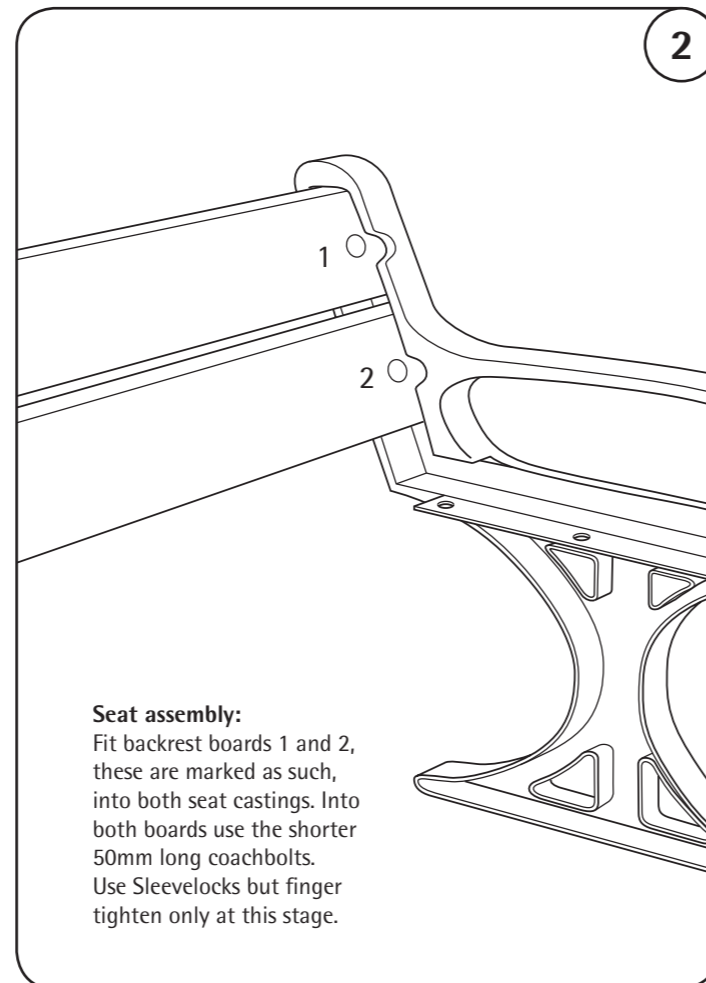

Seat assembly:
Fit backrest boards 1 and 2, these are marked as such, into both seat castings. Into both boards use the shorter 50mm long coachbolts. Use SleeveLocks but finger tighten only at this stage.

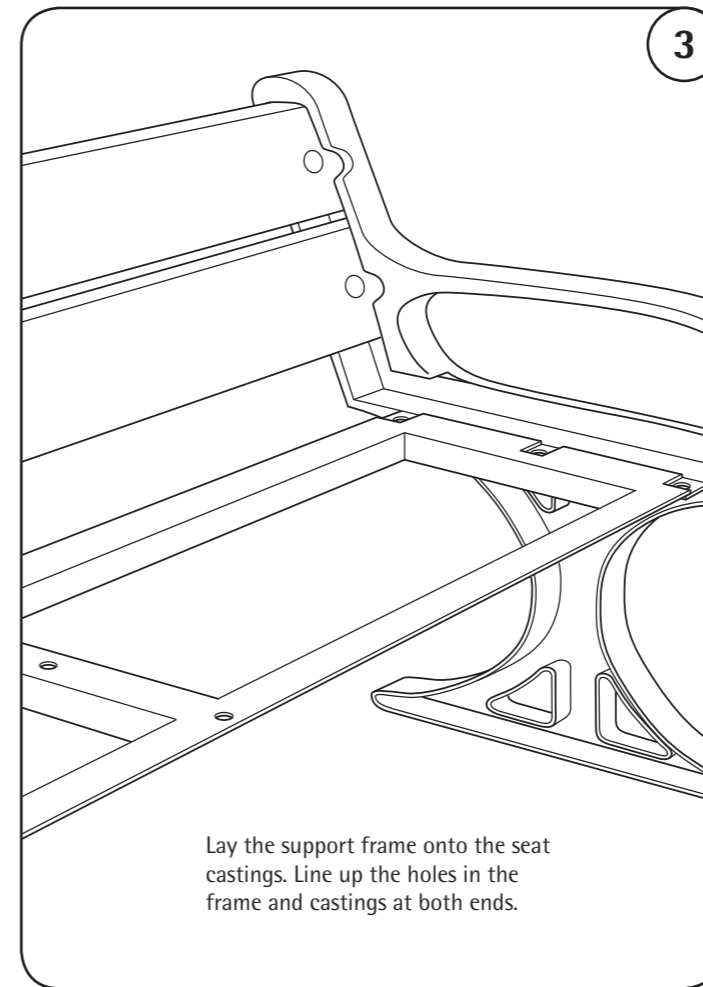

Lay the support frame onto the seat castings. Line up the holes in the frame and castings at both ends.

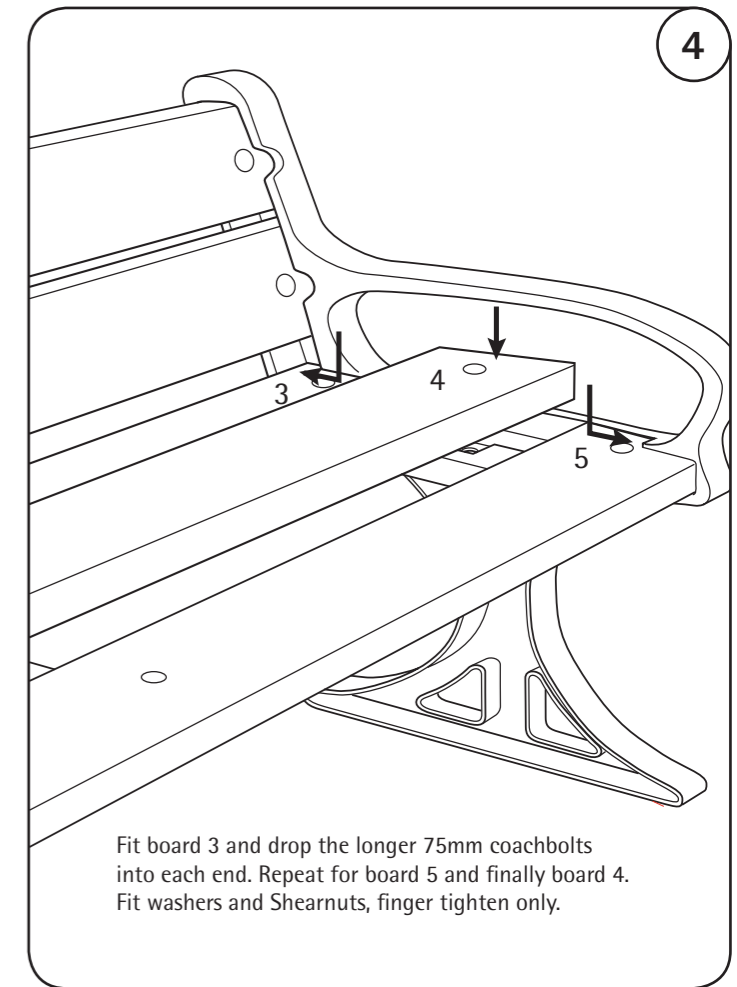

Fit board 3 and drop the longer 75mm coachbolts into each end. Repeat for board 5 and finally board 4. Fit washers and Shearnuts, finger tighten only.

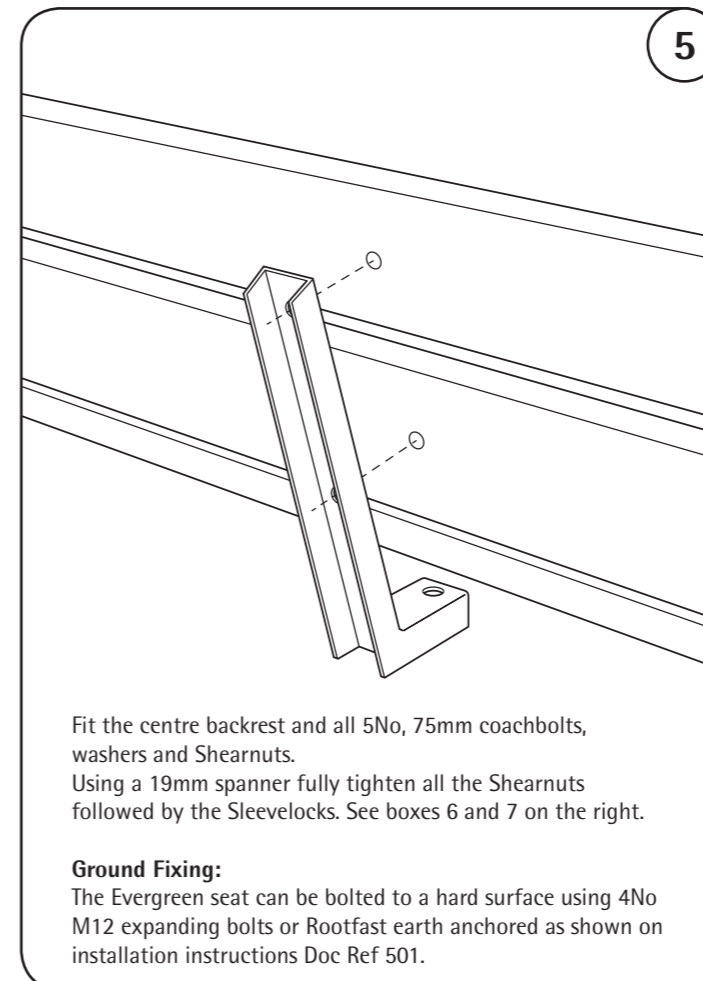

Fit the centre backrest and all 5 No. 75mm coachbolts, washers and Shearnuts. Using a 19mm spanner fully tighten all the Shearnuts followed by the SleeveLocks. See boxes 6 and 7 on the right.

Ground Fixing:
The Evergreen seat can be bolted to a hard surface using 4 No M12 expanding bolts or Rootfast earth anchored as shown on installation instructions Doc Ref 501.

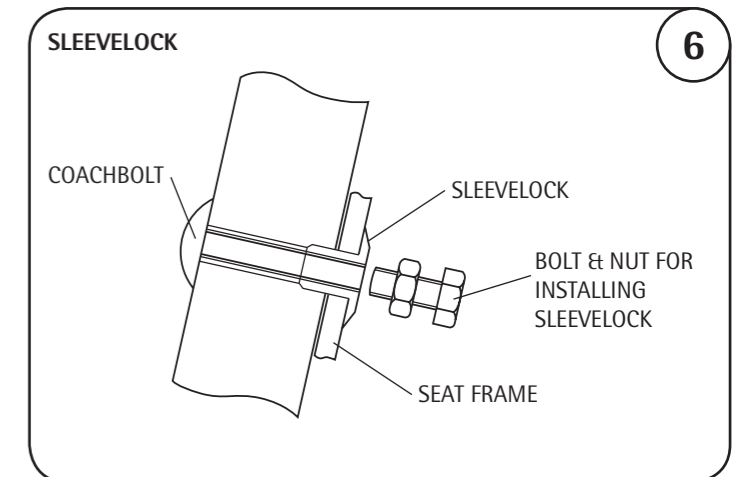

SLEEVELOCK
COACHBOLT
SLEEVELOCK
BOLT & NUT FOR INSTALLING SLEEVELOCK
SEAT FRAME

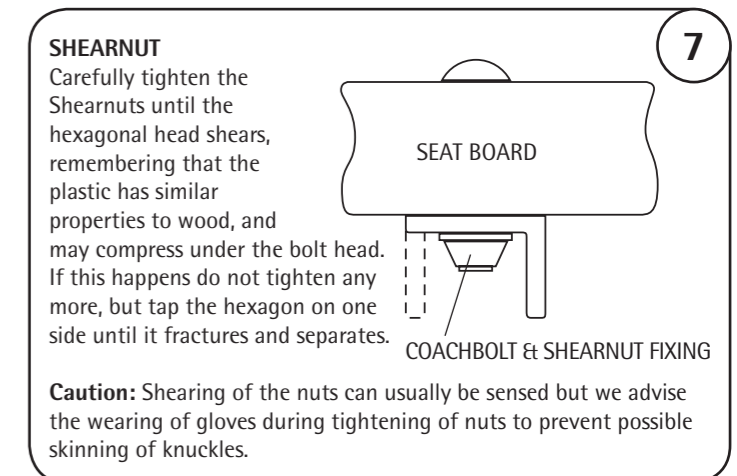

SHEARNUT
Carefully tighten the Shearnuts until the hexagonal head shears, remembering that the plastic has similar properties to wood, and may compress under the bolt head. If this happens do not tighten any more, but tap the hexagon on one side until it fractures and separates.
SEAT BOARD
COACHBOLT & SHEARNUT FIXING

Caution: Shearing of the nuts can usually be sensed but we advise the wearing of gloves during tightening of nuts to prevent possible skinning of knuckles.